



Pike

F-032



- Versatile IEEE 1394b camera
- Advanced feature set
- Many variants
- High frame rates

High-end FireWire

Fast 1394b cameras with high frame rates and powerful features

Pike F-032 搭载 ON Semi KAI-0340 传感器，在 0.3 MP 分辨率下速度可达 208.0 帧/秒。

The Pike is a fast IEEE 1394b camera for demanding applications (e.g. industrial and medical imaging). Numerous pre-processing functions produce an outstanding image quality. Pike cameras operate with very high frame rates.

Pike cameras include extraordinary image pre-processing functions like the High SNR mode (up to 24 dB better signal-to-noise ratio).

Pike cameras are available both with two copper ports (for daisy-chaining) and with copper/GOF (glass optical fiber) ports.

- Sony and OnSemi CCD sensors (1/3, 1/2, 2/3, 1, 1.2, 35 mm)
- 8 models (VGA to 16 Megapixel)
- Options
 - 1394b connectors: daisy chain copper or copper and GOF
 - Various IR cut/pass filters
 - F/M39-Mount (F-032 only: CS/M12-Mount)
 - Pike F-1100/F-1600: M42/M58-Mount
 - Hirose power: out
 - Angled head
 - White medical housing
 - Sensor variants: Taped cover glass w/o microlenses, fixed quartz cover glass w/o microlenses available for some models

性能参数

Pike F-032	
接口	IEEE 1394b - 800 Mb/s, 2 ports, daisy chain, fiber optic (GOF) optional
分辨率	640 (H) × 480 (V)
传感器	ON Semi KAI-0340
传感器类型	CCD Progressive
传感器尺寸	Type 1/3
像元尺寸	7.4 μm × 7.4 μm
标准镜头接口	C-Mount
最大满帧帧率	208 fps
ADC	14 Bit
缓存 (RAM)	64 MByte
输出	
Bit 位数	8-14 bit Bit
黑白像素格式	Mono8, Mono12, Mono16
RGB 彩色像素格式	RGB8
原始像素格式	Raw8, Raw12, Raw16
通用输入输出 (GPIOs)	
光耦 I/Os	2 inputs, 4 outputs
RS232	1
工作条件/尺寸	
工作温度	+5 °C to +50 °C
电源要求 (DC)	8 V to 36 V
功耗	4 W (@ 12 VDC)
重量	250 g
尺寸 (L × W × H in mm)	96.8 × 44 × 44 (including connectors)
符合规范	CE: 2014/30/EU (EMC), 2011/65/EU, including amendment 2015/863/EU (RoHS); FCC Class B

量子转换效率

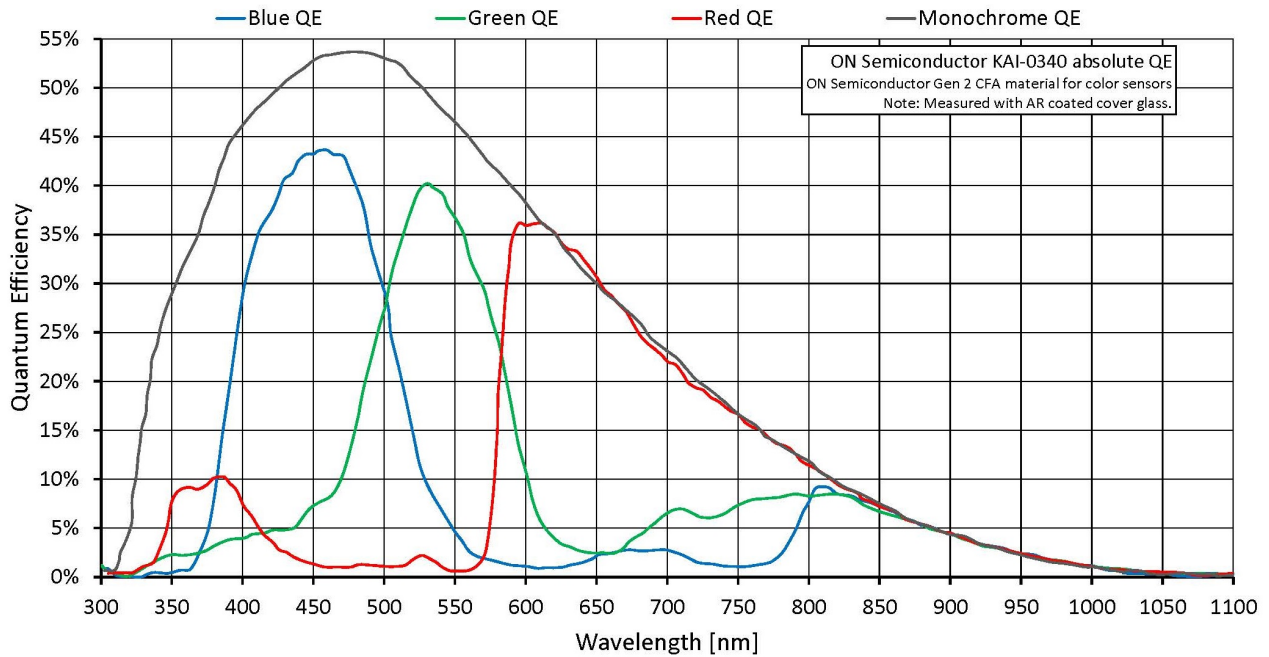

特性

- High SNR mode (up to 24 dB better signal-to-noise ratio)
- Low-Noise Binning Mode
- Smear reduction
- Shading correction
- Area of interest (AOI), separate AOI for auto features
- Binning
- Decimation
- Auto gain (manual gain control: 0 to 22 dB)
- Auto exposure (18 μ s to 67 s)
- Auto white balance
- Look-up table (LUT)
- Hue, saturation, color correction
- Reverse X

- Deferred image transport
- Trigger programmable, level, single, bulk, programmable delay
- Sequence mode (changes the camera settings on the fly)
- SIS (secure image signature, time stamp for trigger, frame count etc.)
- Storable user sets

外形尺寸

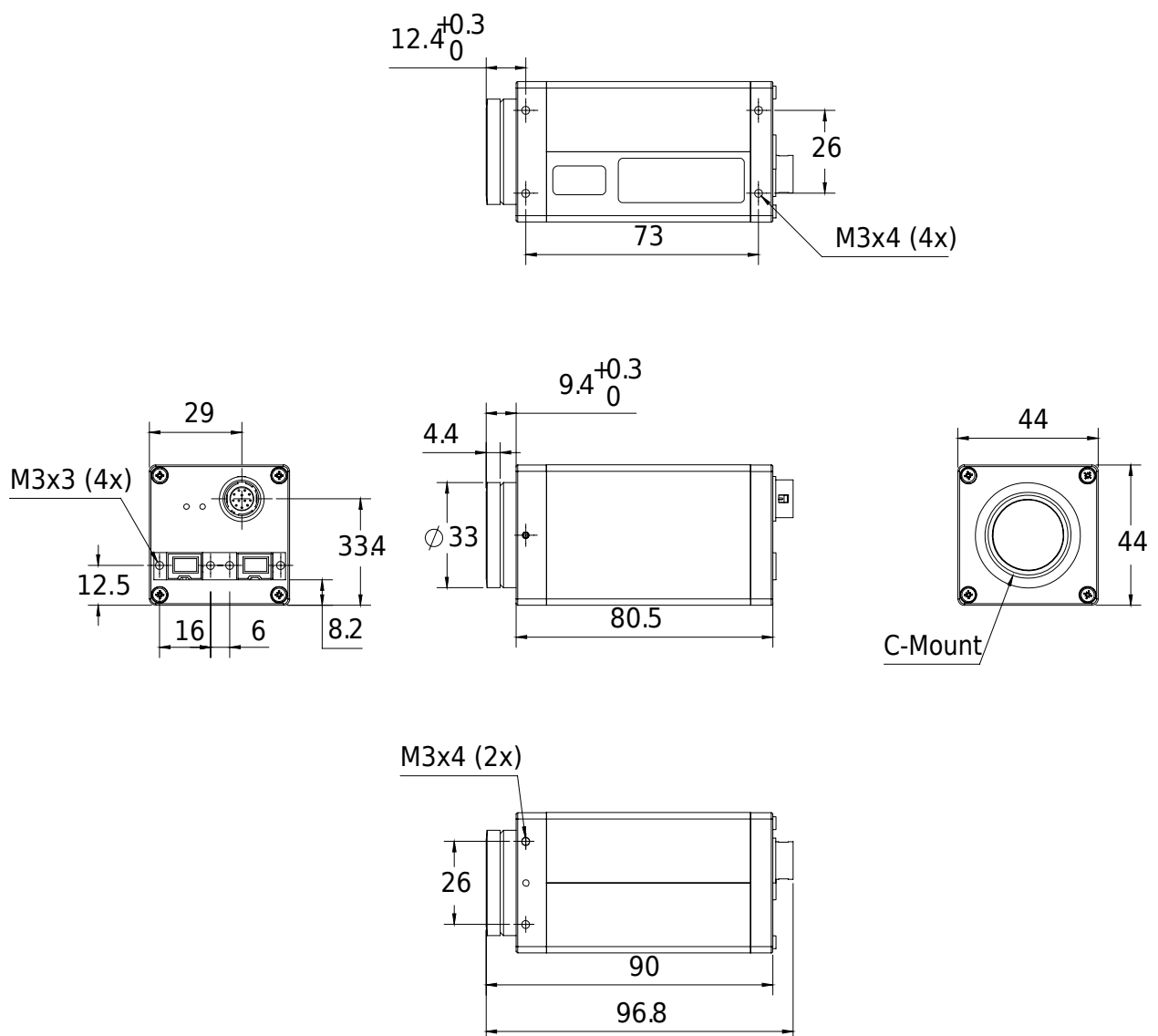

应用场景

The Pike F-032B/F-032C combines a very high frame rate of 208 frames per second with elaborate image pre-processing functions and a fast IEEE 1394b FireWire port. The modular design of the Pike provides many opportunities for customization. This Pike camera is especially suited for:

- Applications which require high frame rates and outstanding image quality
- OEM applications (modular concept)
- Sports, motion studies
- 3D recordings of still and moving objects
- 3D scanning
- Science and research
- Healthcare
- Multimedia and entertainment
- Intelligent traffic solutions (ITS)
- Long cable lengths, 400 meters and more (fiber version)