

Prosilica GS 1380



- Right-angle CCD camera with low height profile
- 30 fps @ full resolution
- Video-type auto iris
- Landscape or portrait sensor orientation

1.4 Megapixel CCD camera with GigE Vision, High sensitivity

Prosilica GS1380 is a very sensitive, high-resolution CCD camera with Gigabit Ethernet interface. This camera incorporates the Sony ICX285 CCD sensor with EXview technology. This camera is available in landscape or portrait orientation. At full resolution, this camera has a frame rate of 30 frames per second. With a smaller region of interest higher frame rates are possible. By default monochrome models ship with no optical filter and color models ship with an IRC30 IR cut filter.

性能参数

Prosilica GS	1380
接口	IEEE 802.3 1000baseT
分辨率	1360 (H) × 1024 (V)
传感器	Sony ICX285
传感器类型	CCD Progressive
Shutter mode	Global shutter
传感器尺寸	Type 2/3
像元尺寸	6.45 μm × 6.45 μm
Lens mount (default)	C-Mount
最大满帧帧率	30 fps
ADC	14 Bit
缓存 (RAM)	16 MByte
	输出
Bit位数	8/12 Bit
黑白像素格式	Mono8, Mono12, Mono12Packed
YUV彩色像素格式	YUV411Packed, YUV422Packed, YUV444Packed

Prosilica GS	1380
RGB彩色像素格式	RGB8Packed, BGR8Packed
原始像素格式	BayerRG8, BayerRG12, BayerGR12Packed
通用输入输出(GPIOs)	
TTL I/Os	1 input, 1 output
光耦 I/Os	1 input, 1 output
RS232	1
工作条件/尺寸	
工作温度	0 °C to +70 °C ambient (without condensation)
电源要求 (DC)	5 to 25 VDC
功耗	3.5 W at 12 VDC
重量	187 g
尺寸 (L × W × H in mm)	96 × 56 × 26 (including connectors)
符合规范	CE: 2014/30/EU (EMC), 2011/65/EU, including amendment 2015/863/EU (RoHS); FCC Class A

量子转换效率

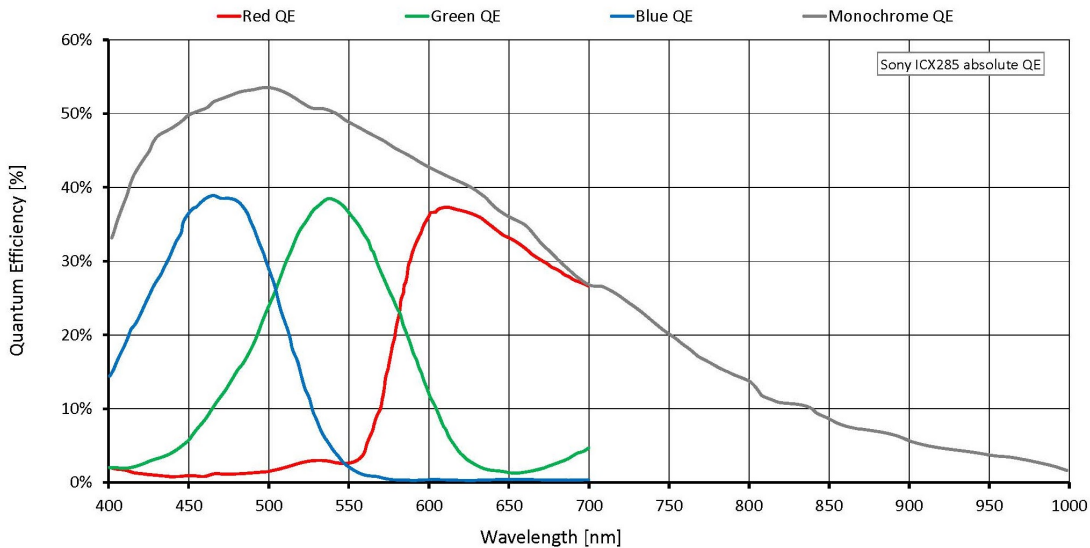

特性

Prosilica GS1380 features include:

- Auto-iris (video type)
- Region of interest (ROI), DSP subregion (selectable ROI for auto features)



- Binning (Sum)
- Auto gain (manual gain control: 0 to 30 dB)
- Auto exposure (manual exposure controls: 10 μ s to 78.5 s)
- Auto white balance
- StreamBytesPerSecond (bandwidth control)
- Stream hold
- Sync out modes: Trigger ready, input, exposing, readout, imaging, strobe, GPO
- Global shutter (digital shutter)
- Recorder and Multiframe acquisition modes
- Event channel
- Image chunk data
- Storable user sets

外形尺寸

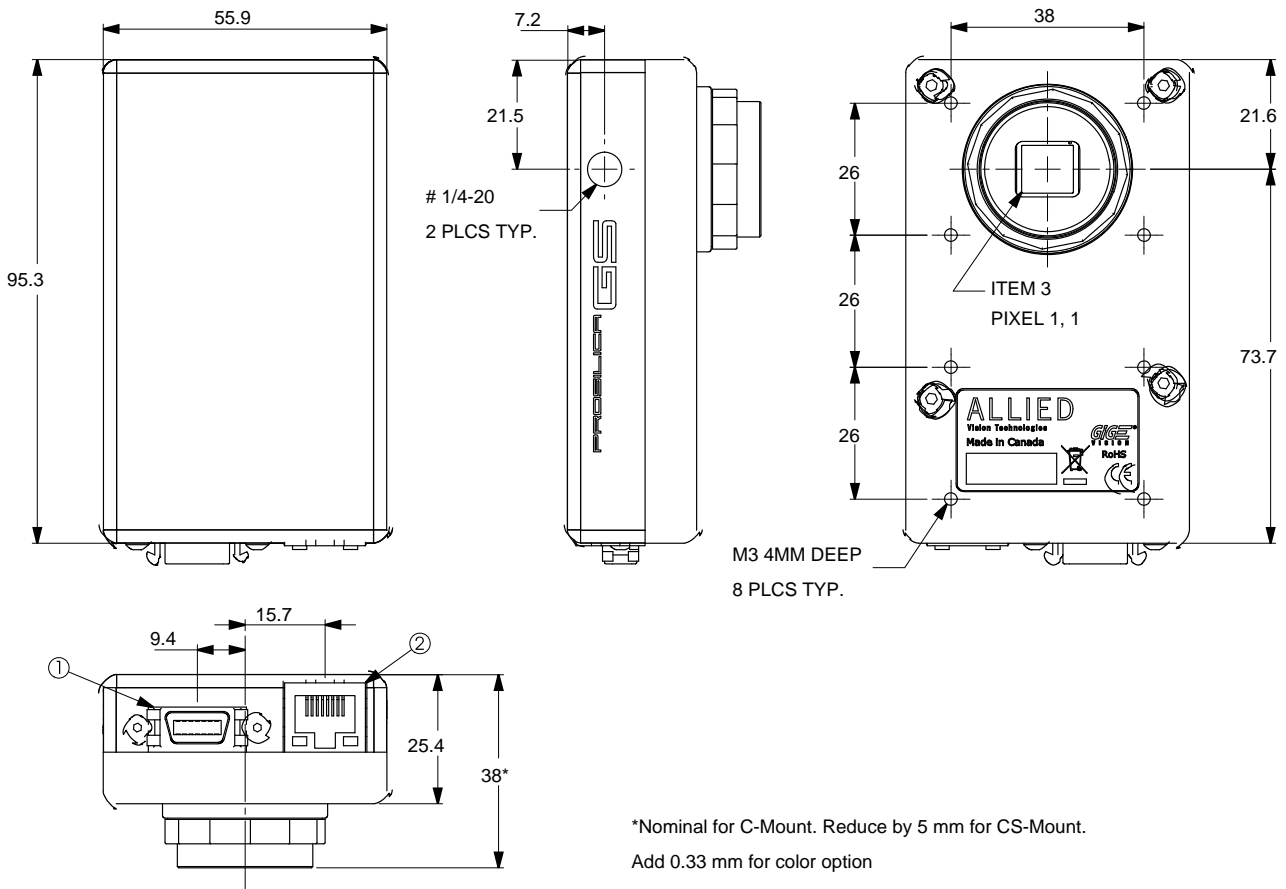



应用场景

Prosilica GS1380 is ideal for a wide range of applications including:

- Industrial inspection
- Machine vision
- Microscopy
- Ophthalmology
- Fluorescence
- Aeronautical and aerospace
- Public security
- Surveillance