



Alvium 1800 C -158

- IMX273 CMOS sensor
- ALVIUM image processing
- MIPI CSI-2 interface
- Various hardware options

Embedded vision CSI-2 camera with IMX273 sensor

Alvium CSI-2 cameras enable new designs for embedded applications with improved image quality and reduced workload for the host. The innovative ALVIUM System on Chip (SoC) performs image corrections and preprocessing tasks onboard the camera instead of the host computer. Unlike FPGAs commonly used in machine vision cameras, the ALVIUM SoC is extremely power efficient. With Alvium, integrating hardware and software can be done effortlessly, which ultimately reduces development time. The Sony IMX273 CMOS sensor enables imaging at 1.6 megapixel and 150 frames per second. Color models ship with an IR cut filter, monochrome and S-Mount models ship without a filter or protection glass.

Benefits and features

- Monochrome (1800 C-158m) and color (1800 C-158c) models
- ALVIUM® Technology for on-board image processing
- MIPI CSI-2 interface with up to 4 lanes
- Platform concept that enables the operation of different Alvium camera models with a common software
- Hirose HR FHH55 FPC connector with minimum space requirements for a compact design
- Precise sensor-to-lens mount alignment
- Standard M3 mounting holes for top and bottom mounting, standard M2 mounting holes for front mounting
- Industrial performance for embedded vision applications
- Easy-to-install [driver and code examples](#)

Hardware options

- Housing: Bare board or open housing
- Various lens mounts: C-Mount, CS-Mount, or S-Mount

For more information on hardware options, including product codes and technical data, such as technical drawings and mass, see the [Alvium Cameras Hardware Options](#) document.

Available accessories

- Tripod adapter
- Adapter boards, such as for Nitrogen6_MAX and Wandboard i.MX6
- FPC cables in 120 mm, 220 mm, and 420 mm length
- Various lenses and Allied Vision S-Mount lenses with focal lengths 2.97 - 12 mm

性能参数

Alvium 1800 C	-158
接口	MIPI CSI-2, up to 4 lanes
分辨率	1456 (H) × 1088 (V)
Spectral range	300 to 1100 nm
传感器	Sony IMX273
传感器类型	CMOS
Shutter mode	Global shutter
传感器尺寸	Type 1/2.9
像元尺寸	3.45 μm × 3.45 μm
Lens mounts (available)	C-Mount, CS-Mount, S-Mount
最大满帧帧率	150 fps using 2 to 4 lanes, RAW8
ADC	12 Bit
缓存 (RAM)	256 KB
非易失性内存 (Flash)	1024 KB
	输出
Bit位数	Max. 12 Bit
YUV彩色像素格式	YUV422_8
RGB彩色像素格式	BGR888, RGB888
原始像素格式	RAW8
	工作条件/尺寸
工作温度	+5 °C to +65 °C housing temperature (with heat sink)
电源要求 (DC)	5 VDC over MIPI CSI-2
功耗	Typical: 2.4 W
重量	10 g (bare board)

Alvium 1800 C	-158
尺寸 (L × W × H in mm)	7 × 26 × 26 (bare board)
符合规范	2011/65/EU, including amendment 2015/863/EU (RoHS)

量子转换效率

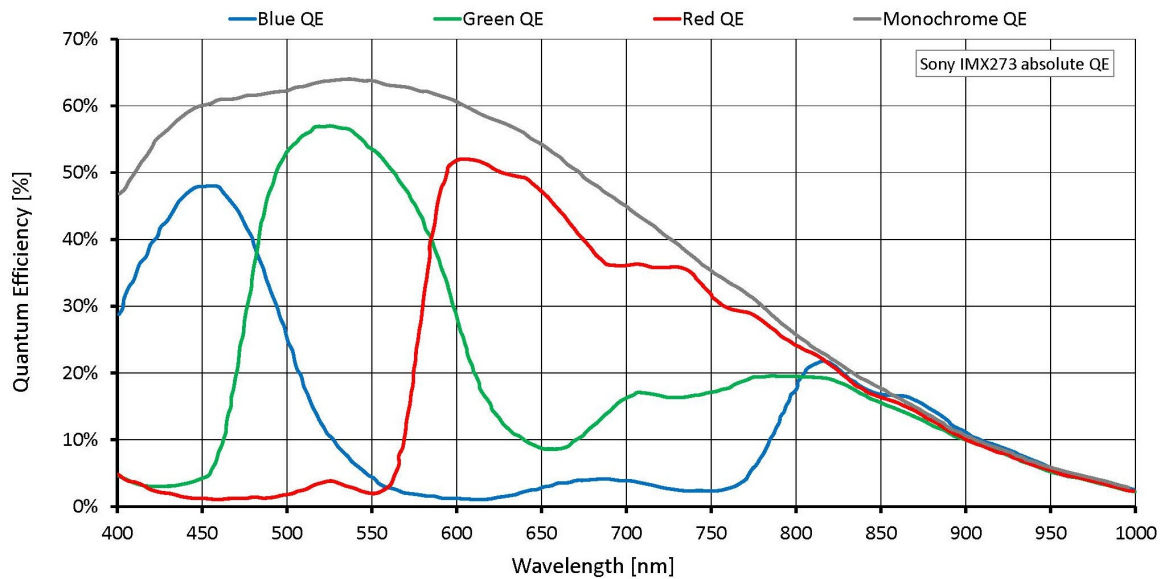

特性

Image control

Auto control

- Auto exposure
- Auto gain
- Auto white balance (color models)

Other image controls

- Black level
- De-Bayering up to 5×5 (color models)
- DPC (factory calibrated)
- Exposure time
- Gain



- Gamma
- Hue (color models)
- Region of interest (ROI)
- Reverse X/Y
- Saturation (color models)

Camera control

- Temperature monitoring (sensor board)

外形尺寸



Camera hardware options

The [Alvium Cameras Hardware Options](#) document informs about submodels, such as bare board or open housing cameras with different lens mounts.

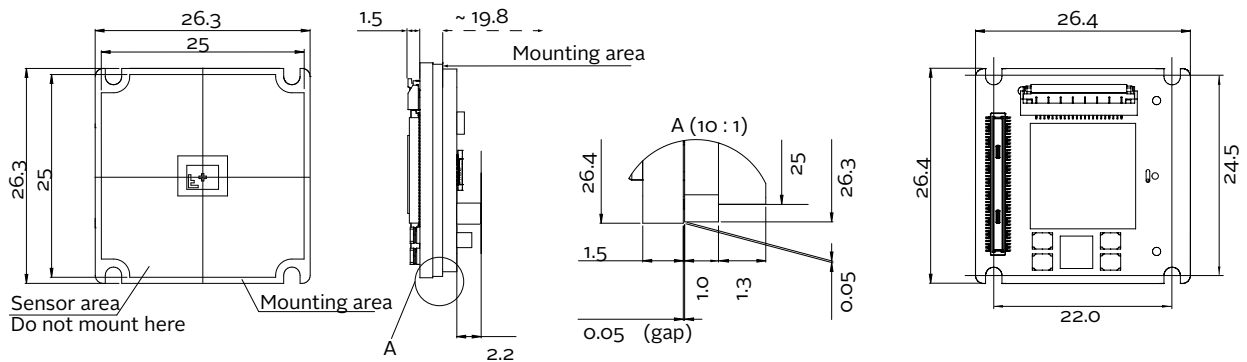

Sensor and electronic components are schematics and vary between models.