

# Prosilica GT 2000

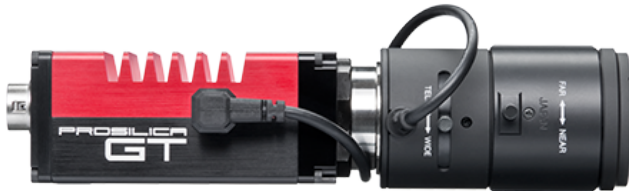

- Versatile temperature range for extreme environments
- IEEE 1588 PTP
- Power over Ethernet
- P-Iris and DC-Iris lens control

## 基本描述

### 2.2 Megapixel machine vision camera for extreme environments

Prosilica GT2000 is a 2.2 Megapixel camera with a GigE Vision compliant Gigabit Ethernet port and Hirose I/O port. Prosilica GT2000 is offered in both monochrome and color models. This camera incorporates the high-quality CMOSIS/ams CMV2000 CMOS sensor. At full resolution, this camera runs 53.7 frames per second. With a smaller region of interest, higher frame rates are possible. It is a rugged camera designed to operate in extreme environments and fluctuating lighting conditions. This camera offers Precise iris lens control allowing users to fix the aperture size to optimize depth of field, exposure, and gain without the need for additional control elements. By default monochrome models ship with no optical filter and color models ship with an IRC30 IR cut filter.

#### Benefits and features:

- Monochrome (GT2000) and color (GT2000C) models
- GigE Vision interface with Power over Ethernet
- Screw mount RJ45 Ethernet connector for secure operation in industrial environments
- Supports cable lengths up to 100 meters (CAT-5e or CAT-6)
- Trigger over Ethernet (ToE) Action Commands allow for a single cable solution to reduce system costs
- Comprehensive I/O functionality for simplified system integration
- Popular C-Mount lens mount
- Easy camera mounting via standard M3 threads or optional tripod adapter
- Easy software integration with Allied Vision's [Vimba SDK](#) and compatibility to the most popular [third party image-processing libraries](#).

## Options:

- Available with CS-Mount, F-Mount, EF-Mount Birger, M42-Mount
- Available with IR cut filter or protection glass

See the [Modular Concept](#) for lens mount and optical filters options. See the [Customization and OEM Solutions](#) page for additional options.

## 性能参数

Prosilica GT	2000
接口	IEEE 802.3 1000BASE-T, IEEE 802.3af (PoE)
分辨率	2048 (H) × 1088 (V)
传感器	CMOSIS/ams CMV2000
传感器类型	CMOS
传感器尺寸	Type 2/3
像元尺寸	5.5 μm × 5.5 μm
标准镜头接口	C-Mount
最大满帧帧率	53.7 fps
ADC	12 bit
缓存 (RAM)	128 MByte
非易失性内存 (Flash)	1024 KByte (for selected models only)
输出	
Bit位数	8/12 bit
黑白像素格式	Mono8, Mono12, Mono12Packed
YUV彩色像素格式	YUV411Packed, YUV422Packed, YUV444Packed
RGB彩色像素格式	RGB8Packed, BGR8Packed, RGBA8Packed, BGRA8Packed
原始像素格式	BayerGB8, BayerGB12, BayerGB12Packed
通用输入输出(GPIOs)	
TTL I/Os	1 input, 2 outputs
光耦 I/Os	1 input, 2 outputs
RS232	1
工作条件/尺寸	
工作温度	-20 °C to +65 °C ambient (without condensation)
电源要求 (DC)	7 to 25 VDC; PoE
功耗	3.4 W at 12 VDC; 4.2 W PoE
重量	210 g
尺寸(L × W × H in mm)	86 × 53.3 × 33 mm (including connectors)

Prosilica GT  
符合规范

2000

CE: 2014/30/EU (EMC), 2011/65/EU, including amendment 2015/863/EU (RoHS); FCC Class A; CAN ICES-003 Issue 4/5

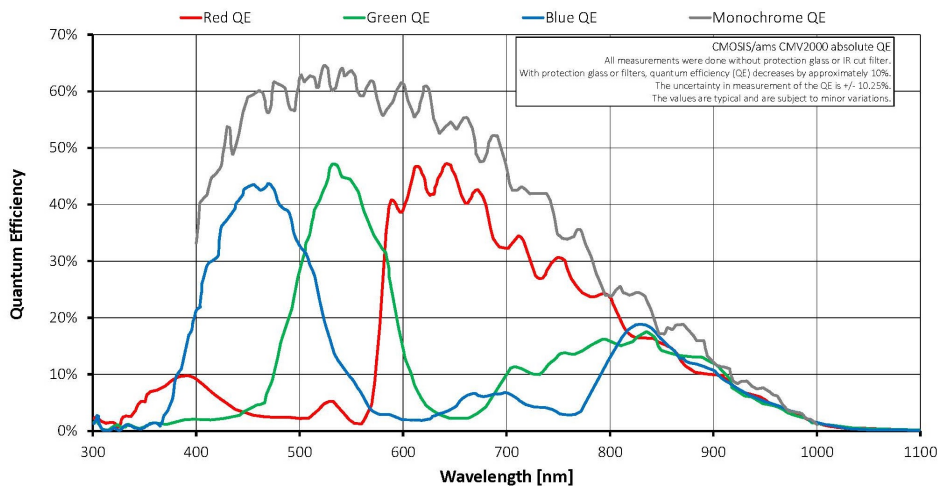

## 特性

### Image optimization features:

- Auto gain (manual gain control: 0 to 26 dB)
- Auto exposure (manual exposure control: 25  $\mu$ s to 122 s)
- Auto white balance (GT2000C only)
- BlackLevel (offset)
- Color correction, hue, saturation (GT2000C only)
- Gamma correction
- Three look-up tables (LUTs)
- Piecewise Linear HDR mode
- Region of interest (ROI), separate ROI for auto features

### Camera control features:

- P-Iris and DC-Iris lens control
- Event channel
- Image chunk data



- IEEE 1588 Precision Time Protocol (PTP)
- RS232
- Storable user sets
- StreamBytesPerSecond (bandwidth control)
- Stream hold
- Sync out modes: Trigger ready, input, exposing, readout, imaging, strobe, GPO
- Temperature monitoring (main board only)
- Trigger over Ethernet (ToE) Action Commands
- Non-volatile memory 1024 KByte (for selected models only)

## 外形尺寸

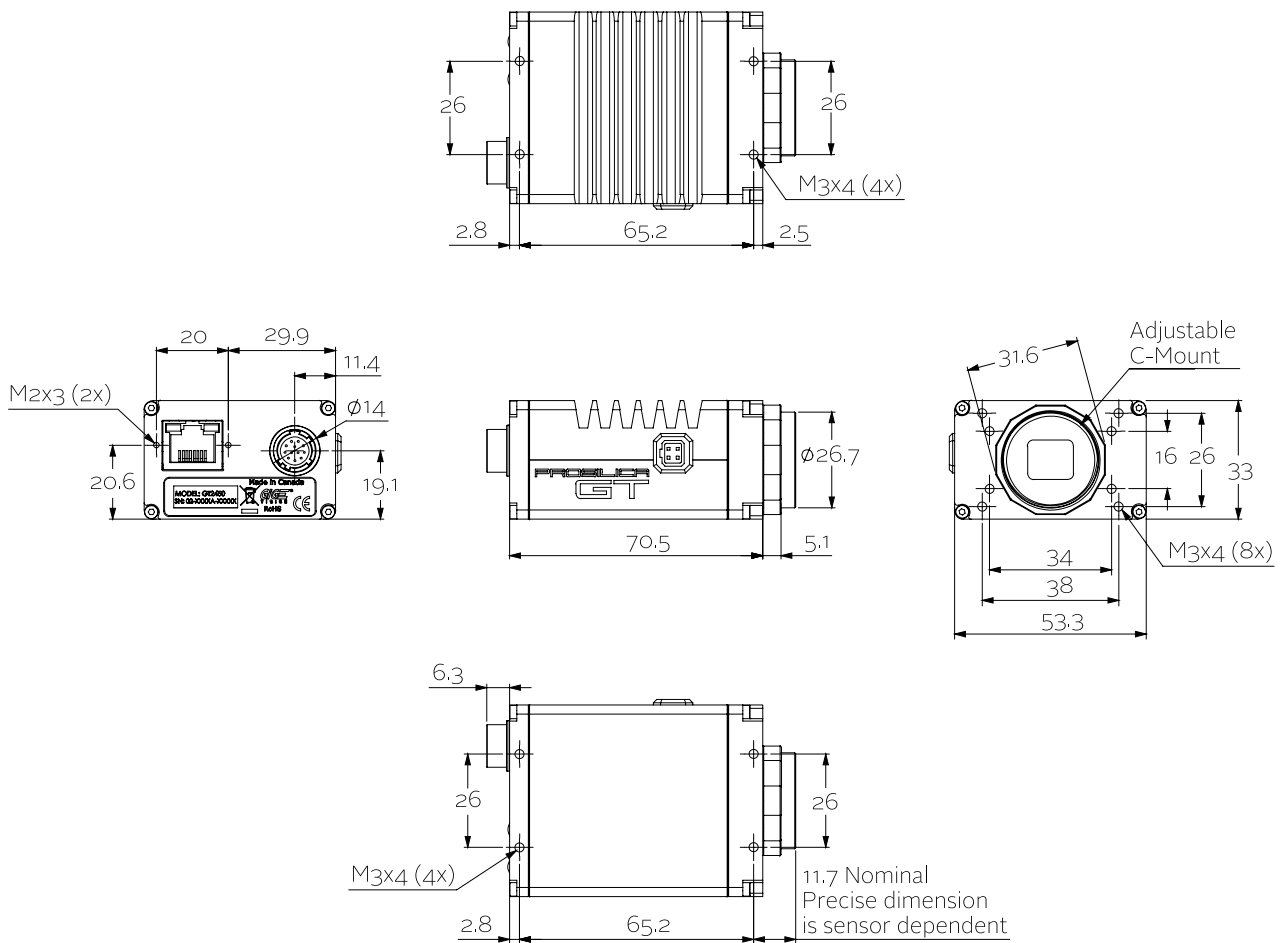



## 应用场景

Prosilica GT2000 is ideal for a wide range of applications including:

- Outdoor imaging
- Traffic imaging and ITS
- Public security and surveillance
- Industrial inspection
- Machine vision
- Military and space applications